

Frein à manque de courant  
**Série HZg**



3 x 230 V - 3 x 400 V - 3 x 500 V - 3 x 690 V

**ELECTROMAGNETIC DISC BRAKES**  
**HZg SERIES**  
**WITH CONSTANT BRAKING TORQUE**



Spring actuated and electromagnetically released disk brake type HZg powered by alternating current. Designed for braking rotating machine parts and their precision positioning. Utilized as safety brake. High repeatability even with large number of actuations. The brake characterizes relatively simple construction, facility for regulating brake parameters such as braking torque, braking time and also possibility of supply from alternating current source after connecting up a rectifier circuit delivered at customer's request along with the brake. An additional feature is quiet operation, particularly important when the equipment is operated by a number of drives operating additionally with high frequency of actuations. Brake design guarantees simple and problem-free installation. Various options of executions are at disposal with respect to fittings/accessories, brake supply, climatic conditions of utilization, enabling selection of appropriate option for definite utilization conditions.



They are distinguished by dynamic operation characteristic for alternating current electromagnetic equipment, hence acquiring very short operating time (braking and releasing), and in spite of complicated structure of the electromagnet, they provide simple control circuit – connection with alternating current source, e.g. with motor connecting box terminals, forming a mechanically and electrically compact structure.

**They are designed for braking rotating parts of machines and their task is:**

- ❖ emergency stopping, in order to ensure drive safety functions,
- ❖ immobilizing machine actuators, acting as a positioning device,
- ❖ minimizing run-on times of drives (to meet safety requirements according to Office of Technical Inspection (UDT) regulations)
- ❖ built onto an electric motor, the brake provides a self-braking motor, a drive unit meeting the requirements of utilisation safety and positioning.

Brakes can be manufactured in variants suitable for various alternating-current voltages: 3x230, 3x400, 3x500, 3x690V which allows them to be supplied from standard alternating current sources.

Parameters		Unit	Brake type				
			H(Z,Y)g 90	H(Z,Y)g 100	H(Z,Y)g112	H(Z,Y)g 132	H(Z,Y)g 160
Supply voltage	Un	[V]	3x230, 3x400, 3x500, 3x690 50 or 60 Hz				
Power	P <sub>20°</sub>	[W]	35	40	60	80	130
Braking torque	M <sub>h</sub>	[Nm]	20	40	60	100	200
Max. speed	n <sub>max.</sub>	min <sup>-1</sup>	3000				
Weight	G	kg	4,7	6,8	10,4	14,5	27,0
Ambient temperature	T	°C	- 25 ÷ + 40				
Operating time *	t <sub>0,1</sub>	ms	10	10	11	15	10
	t <sub>0,9</sub>	ms	10	20	35	30	100

t<sub>0,1</sub> - releasing time (from switching on current to drop in braking torque to 10% M<sub>nom</sub>)  
t<sub>0,9</sub> - braking time (from switching off current to attaining 90% M<sub>nom</sub>)

\*) Values of releasing and braking times are given as approximations, since they depend on mode of assembly/installation, temperature and power supply.

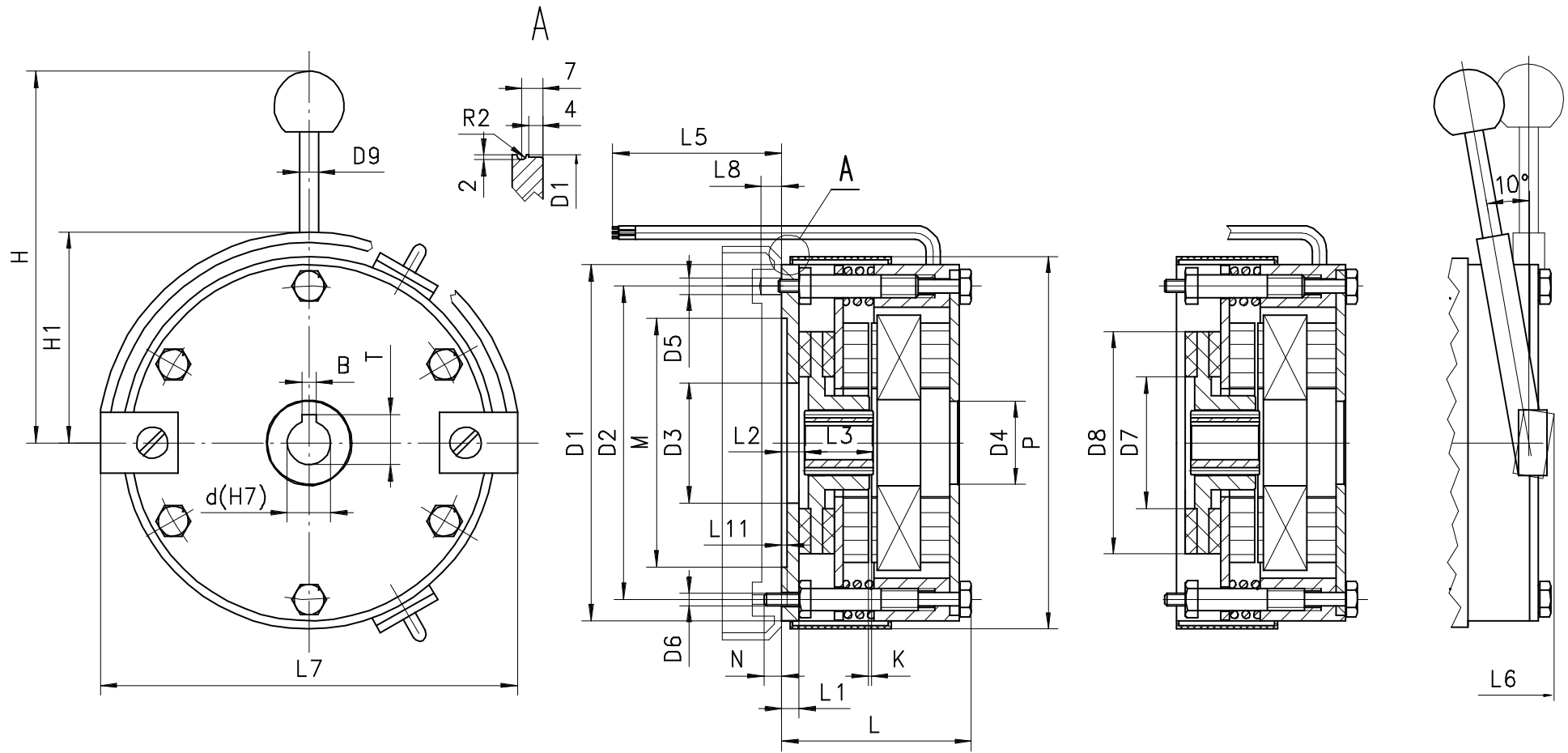

Type	D	D1	D2	D3	D4	D5	D6	D7	D8	D9	L	L1	L11	L2	L3	L5	L6	L7	L8	H	H1	M	N	d	d <sub>max</sub>	T	B	K	P
H(Z,Y)g 90	142	138	119	54	25	7	3xM6	74	104	6	93	10	4	11	26	450	97	159	6	146	78	108	12	24	26	27,3	8	0,4	142
H(Z,Y)g 100	159	156	136	54	27	7	3xM6	84	119	6	93	10	4	11	26	450	97	177	6	155	88	118	12	26	26	29,3	8	0,4	159
H(Z,Y)g 112	192	189	164	80	29	9	3xM8	88	144	8	108	10	4	11	34	650	111	210	8	225	108	136	14	28	35	31,3	8	0,4	192
H(Z,Y)g 132	212	209	184	106	36	9	3xM8	110	164	8	123	10	4	11	38	650	126	232	8	295	115	148	14	35	40	38,3	10	0,4	212
H(Z,Y)g 160	270	266	234	134	41	11	3xM10x1,25	140	210	10	137	14	5	14	47	800	144	298	10	330	152	164	16	40	45	43,3	12	0,4	270

**H****g****v****Nm****d**

<b>Z</b>	MOUNTING FLANGE
<b>Y</b>	LEVER FOR MANUAL RELEASE
<b>S</b>	RELEASING SCREWS
<b>ZY</b>	MOUNTING FLANGE, LEVER FOR MANUAL RELEASE
<b>zS</b>	MOUNTING FLANGE, RELEASING SCREWS

MECHANICAL SIZE	
90 , 100 , 112 , 132 , 160	

<b>A</b>	<b>BRAKE WITHOUT HOLE D4 IN ELECTROMAGNET</b>
----------	---

OPERATING VOLTAGE [V AC]	
3x230, 3x400, 3x500V, 3x690    50 or 60 Hz	

NOMINAL BRAKING TORQUE [Nm]				
H(Z,Y)g 90	H(Z,Y)g 100	H(Z,Y)g 112	H(Z,Y)g 132	H(Z,Y)g 160
20	40	60	100	200
13	26	40	66	133
10	20	30	50	100
6,6	13	20	33	66
4,4	9	13	22	44
3,4	7	11	17	33

PROTECTION RATING	
<b>IP 44</b>	Basic version
<b>IP 54</b>	V-ring sealing
<b>IP 55</b>	Additional sealing + V-ring
<b>IP 56</b>	Special sealing + brake cover

CLIMATIC VERSION
ACCORDING TO STANDARDS : e.g. MT, TH

**DIAMETER OF SLEEVE GEAR d(H7)**

**EXAMPLE :**

HZg 132 . 3x400V 50Hz 100Nm IP54 d35

**The producer reserves the right to modify as a result of developing the product.  
It is possible to realize special versions.**