

Frein courant continu
Série HPS



24 VDC - 104 VDC - 180 VDC - 207 VDC

ELECTROMAGNETIC DISC BRAKES

HPS SERIES

WITH REGULATING BRAKING TORQUE



Spring actuated and electromagnetically released disk brake type HPS powered by direct current. Designed for braking rotating machine parts and their precision positioning. Utilized as safety brake. High repeatability even with large number of actuations. The brake characterizes relatively simple construction, facility for regulating brake parameters such as braking torque, braking time and also possibility of supply from alternating current source after connecting up a rectifier circuit delivered at customer's request along with the brake. An additional feature is quiet operation, particularly important when the equipment is operated by a number of drives operating additionally with high frequency of actuations. Braking torque can be accurately set by means of regulating nut. Brake design guarantees simple and problem-free installation. Various options of executions are at disposal with respect to fittings/accessories, brake supply, climatic conditions of utilization, enabling selection of appropriate option for definite utilization conditions.



They are designed for braking rotating parts of machines and their task is:

- ❖ emergency stopping, in order to ensure drive safety functions,
- ❖ immobilizing machine actuators, acting as a positioning device,
- ❖ minimizing run-on times of drives (to meet safety requirements according to Office of Technical Inspection (UDT) regulations,
- ❖ built onto an electric motor, the brake provides a self-braking motor, a drive unit meeting the requirements of utilisation safety and positioning.

Brakes can be manufactured in variants suitable for various direct-current voltages: 24V, 104V, 180V, 207V which allows them to be supplied from standard alternating current sources, through appropriate rectifier.

Parameters		Unit	Brake type										
			HPS 04	HPS 06	HPS 08	HPS 10	HPS 12	HPS 14	HPS 16	HPS 18	HPS 20	HPS 25	
Supply voltage	Un	[V]	24 , 104 , 180 , 207 VDC										
Power	P _{20°}	[W]	16	20	25	30	40	50	55	65	75	130	
Braking torque	M _h	[Nm]	4	4	8	20	32	60	100	150	240	500	
Max. speed	n _{max.}	min ⁻¹	3000										
Weight	G	kg	0,5	0,7	1,8	3,2	6,6	7,5	11,2	17,0	24,8	29,0	
Ambient temperature		°C	-25 ÷ +40										
Operating time *	On direct voltage side	t _{0,1}	ms	20	35	65	90	120	150	180	300	400	500
		t _{0,9}	ms	10	17	35	40	50	65	90	110	200	270
	On alternating voltage side	t _{0,1}	ms	20	35	65	90	120	150	180	300	400	500
		t _{0,9}	ms	Brake disconnection on alternating current side causes about five-times growth in braking time t ₀₉ with respect to disconnection on direct current side									

t_{0,1} - releasing time (from switching on current to drop in braking torque to 10% M_{nom})
t_{0,9} - braking time (from switching off current to attaining 90% M_{nom})

*) Values of releasing and braking times are given as approximations, since they depend on mode of assembly/installation, temperature and power supply.

Cable output:

A – HPS12, HPS14, HPS16, HPS18, HPS20

B – HPS04, HPS06, HPS08, HPS10, HPS25

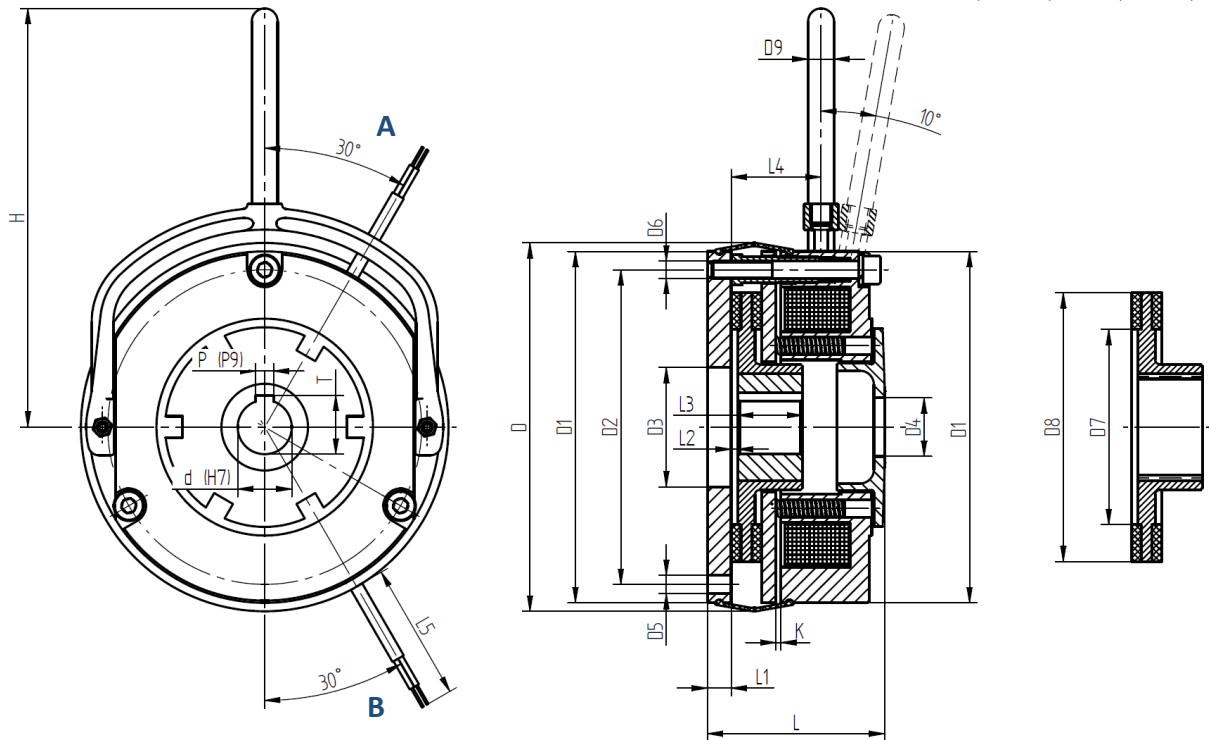

Type	M _h [Nm]	D	D1	D2	D3	D4	D5	D6	D7	D8	D9	L	L1	L2	L3	L4	L5	L6	K	H	H1
HPS04	4	83	74	62	25	13	Ø4,3x3	M4x3	30	50	6	45	6	0,5	18	23	450	6,7	0,2	98	46
HPS06	4	91	84	72	25	17	Ø4,5x3	M4x3	47	62	8	45	6	0,5	18	24	450	6,7	0,2	100	51
HPS08	8	110	102	90	30	17	Ø5,5x3	M5x3	59	76	8	53	7	1,8	20	29	450	6,7	0,2	111	61
HPS10	16	133	125	112	44	21	Ø6,4x3	M6x3	61	95	10	65	9	3,5	20	37	450	9,0	0,2	160	73
HPS12	32	156	148	132	45	27	Ø6,4x3	M6x3	74	114	10	74	9	3	25	40,5	450	9,0	0,3	181	94
HPS14	60	170	162	145	55	27	Ø8,4x3	M8x3	90	124	12	82	11	3	30	41,5	450	9,0	0,3	193	102
HPS16	100	196	188	170	84	38	Ø8,4x3	M8x3	100	154	12	89	11	3	30	43,5	450	9,0	0,3	206	116
HPS18	150	223	215	196	104	43	Ø9,0x4	M8x6	130	176	12	100	11	3	35	51	450	11,0	0,3	237	129
HPS20	240	262	252	230	134	45	Ø11x6	M10x6	148	207	14	120	11	3	40	68	800	11,0	0,5	339	157
HPS25	500	314	302	278	120	45	Ø11x6	M10x6	198	255	14	134	12,5	4,5	50	82	800	11,0	0,5	466	182

Geared bushing hole diameters

Normalized hole diameter ranges

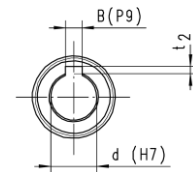
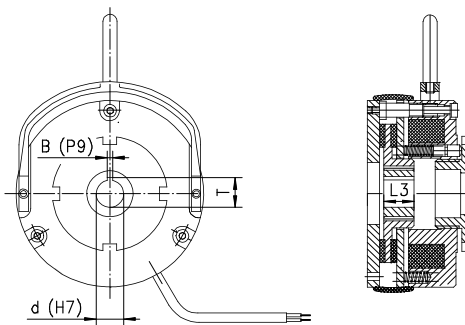

Type	d	B	T	d _{max}	d _{smax} *	L3
HPS04	11	4	12,8	11		18
HPS06	15	5	17,3	15		18
HPS08	15	5	17,3	15		20
HPS10	19	6	21,8	25		20
HPS12	25	8	28,3	25		25
HPS14	25	8	28,3	35**		30
HPS16	35**	8	38,3	35**		30
HPS18	40	12	43,3	45	50	35
HPS20	42	12	45,3	45	50	40
HPS25	42	12	45,3	45	75	50

Hole diameter [mm]	B	t ₂
above - to		
10 - 12	4	1,8
12 - 17	5	2,3
17 - 22	6	2,8
22 - 30	8	3,3
30 - 38	10	3,3
38 - 44	12	3,3
44 - 50	14	3,8
50 - 58	16	4,3
58 - 65	18	4,4
65 - 75	20	4,9

d - standard geared bushing hole diameters

d_{smax} - maximum geared bushing hole diameters

d*_{smax} - at extra charge it is possible to manufacture the brakes with the specially increased diameter of the gear hub

** - for the HPS14 and HPS16 brakes and for the geared bushing hole diameters from 32 to 35mm, the key groove with the width of 8 mm (the width of the groove is incompatible with PN/M-85005 and DIN 6885 standards)

BEAKES EQUIPMENT

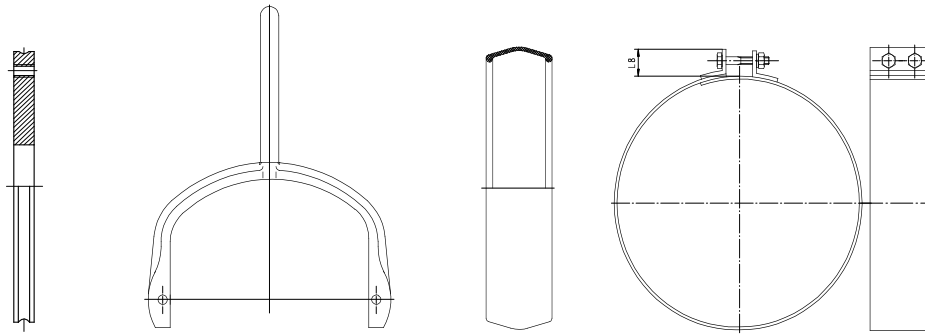

Type	L7
HPS04	9
HPS06	11
HPS08	11
HPS10	9
HPS12	11
HPS14	13
HPS16	13
HPS18	13
HPS20	13
HPS25	13

Mounting flange | Lever for manual release | Brake cover | IP56 brake cover

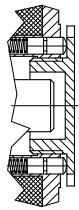

Adjustment nut without a hole

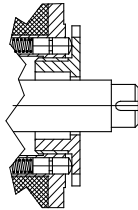

Adjustment nut with a hole

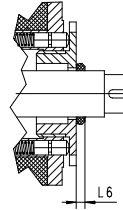

Adjustment nut with a hole and a sealing ring

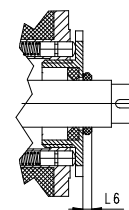

Adjustment nut with a hole and special packing

ELECTRICAL EQUIPMENT

A number of modules, ranging from simple circuits with classic designs, to complex assemblies ensuring quick action and drives positioning have been designed to drive the brakes. Relevant brake applications with switching in the primary or secondary circuits are ensured by half- or full-wave rectifiers and fast electronic circuits. The manufacturer recommends to use as low alternating current voltages as possible to supply the brakes. Appropriate choice of the control voltage will prevent or at least limit surges that may occur in power supply circuits. It is not recommended to use extensively long control wiring, which would be a source of harmful surges.

Rectifier B2-1P

The B2-1P rectifiers series forms a complete wave rectifier unit for direct installation. The terminal strip provided facilitates installation and connection to the circuit.

[Rectifier B2-1P cooperates with brakes HPS04 ÷ HPS25.](#)

RECTIFIER PARAMETERS			
		B2-1P-400	B2-1P-600
Maximum input voltage (alternating voltage AC)	U_{IN}	400 VAC	600 VAC
Maximum output voltage (direct voltage DC)	U_{OUT}	$0,45 U_{IN}$	$0,45 U_{IN}$
Maximum continuous output current rectifier	I_{OUT}	2A	2A

For example

Maximum input voltage (alternating voltage) - $U_{IN} = 230VAC$,

The resulting output voltage of the rectifier (direct voltage) - $0,45 U_{IN} = 0,45 \times 230 = 104VDC$

Rectifier B5-1P

The B5-1P rectifiers series forms a complete wave rectifier unit for direct installation. The terminal strip provided facilitates installation and connection to the circuit.

[Rectifier B5-1P cooperates with brakes HPS04 ÷ HPS25.](#)

RECTIFIER PARAMETERS			
		B5-1P-400	B5-1P-600
Maximum input voltage (alternating voltage AC)	U_{IN}	400 VAC	600 VAC
Maximum output voltage (direct voltage DC)	U_{OUT}	$0,45 U_{IN}$	$0,45 U_{IN}$
Maximum continuous output current rectifier	I_{OUT}	5A	5A

For example

Maximum input voltage (alternating voltage) - $U_{IN} = 230VAC$,

The resulting output voltage of the rectifier (direct voltage) - $0,45 U_{IN} = 0,45 \times 230 = 104VDC$

Rectifier B2-2P

The B2-2P rectifiers series forms a complete full-wave rectifier unit for direct installation. The terminal strip provided facilitates installation and connection to the circuit. The rectifier allows feeding input voltage max. 400VAC, 2A which after rectification provides DC voltage of value equal to 0,9 input voltage.

[Rectifier B2-2P cooperates with brakes HPS04 ÷ HPS25.](#)

RECTIFIER PARAMETERS		
Maximum input voltage (alternating voltage AC)	U_{IN}	250 VAC
Maximum output voltage (direct voltage DC)	U_{OUT}	$0,9U_{IN}$
Maximum continuous output current rectifier	I_{OUT}	2A

For example

Maximum input voltage (alternating voltage) - $U_{IN} = 230VAC$,

The resulting output voltage of the rectifier (direct voltage) - $0,9U_{IN} = 0,9 \times 230 = 207VDC$

Rectifiers dimensions

**B2-1P-400,
B5-1P-400,
B2-2P**

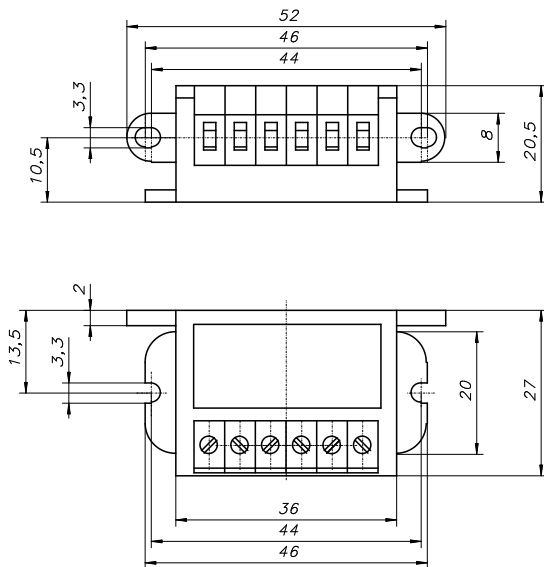

**B2-1P-600,
B5-1P-600**

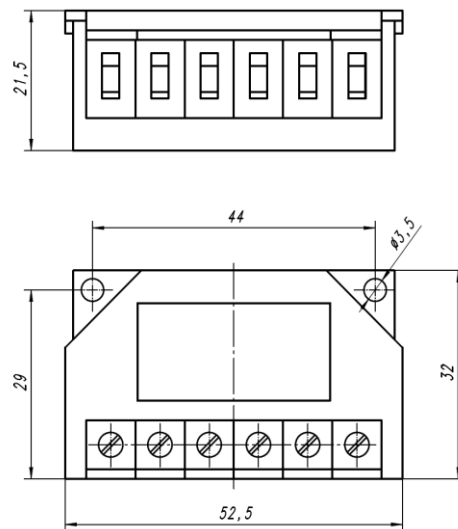

Disconnection of power supply on AC side

The diagram presents connection of rectifiers to supply circuit of motor. When disconnecting the voltage, the magnetic field causes the coil current to flow further through the rectifying diodes and drops slowly. The magnetic field reduces gradually causing prolonged time of braking action and consequently delayed increase of braking torque. If action time is irrelevant, brake should be connected on the AC side. When switching off, the supply circuits act as rectifying diodes.

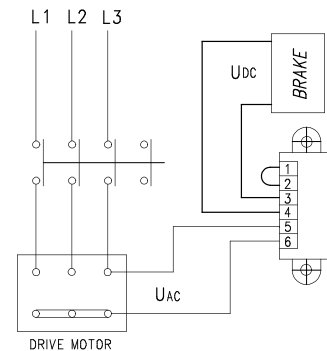

Disconnection of power supply on DC side

The diagram presents connection of rectifiers into electric motor circuit. The coil current is interrupted between the coil and supply (rectifier) circuit. The magnetic field reduces very quickly, **giving short time of braking action and consequently rapid growth of braking torque.** When switching off on DC voltage side, a high peak voltage is generated in the coil causing faster wear of contacts due to sparking. For protecting the coil against peak voltages and protecting the contacts against excessive wear, the rectifier circuit is provided with protective facility allowing brake connection on DC voltage side.

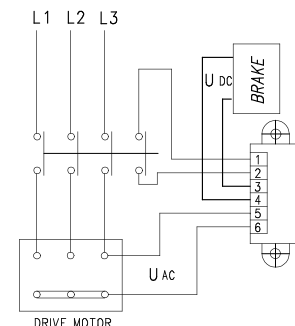

Rectifier PS-1

Circuit PS-1 is built on the basis of MOSFET type semiconductor technique which enabled achieving effects not available in traditional designs. The brake electromagnet energized through circuit of this construction enables the brake to achieve connection and disconnection time parameters analogous to breaking of circuit on direct current side. The parameters obtained are not however gained through utilization of additional electrical circuits and switches.

Simplicity of installation and parameters achieved enable very wide application, particularly in cases requiring positioning of drives, operation with high frequency of actuations compounded with repeatability of brake connecting and disconnecting times.

Supply circuit PS-1 forms a complete unit for direct installation. Provided with a four-terminal strip, it enables unhindered adaptation in every cooperating circuit. The circuit is adapted for supply from alternating current source of 380-400 VAC max. 420 VAC which after rectification and appropriate formation enables obtaining direct voltage of 170-180 VDC for brake supply.

The diagram below shows the method of connecting the circuit PS 1 into supply circuit of brake cooperating with 3x400 VAC electric motor with star-connected winding.

[Rectifier PS-1 cooperates with brakes HPS04 ÷ HPS20.](#)

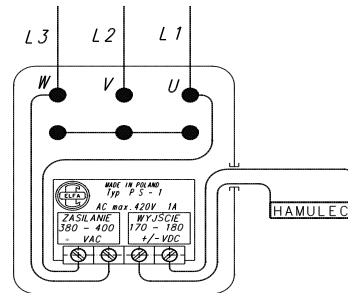

Rectifier PS-2

Circuit PS-2 is built on the basis of MOSFET type semiconductor technique which enabled achieving effects not available in traditional designs. The brake electromagnet energized through circuit of this construction enables the brake to achieve connection and disconnection time parameters analogous to breaking of circuit on direct current side. The parameters obtained are not however gained through utilization of additional electrical circuits and switches.

Simplicity of installation and parameters achieved enable very wide application, particularly in cases requiring positioning of drives, operation with high frequency of actuations compounded with repeatability of brake connecting and disconnecting times.

Supply circuit PS 2 forms a complete unit for direct installation. Provided with a four-terminal strip, it enables unhindered adaptation in every cooperating circuit. The circuit is adapted for supply from alternating current source of 220-230 VAC max. 250 VAC which after rectification and appropriate formation enables obtaining direct voltage of 190-207 VDC for brake supply.

The diagram below shows the method of connecting the circuit PS 2 into supply circuit of brake cooperating with 3x400 VAC electric motor with star-connected winding.

[Rectifier PS-2 cooperates with brakes HPS04 ÷ HPS25.](#)

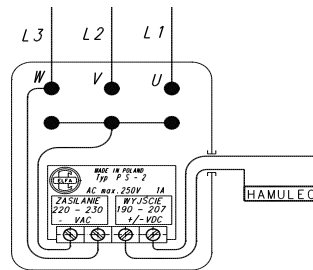

Rectifiers PS-1, PS-2 dimensions

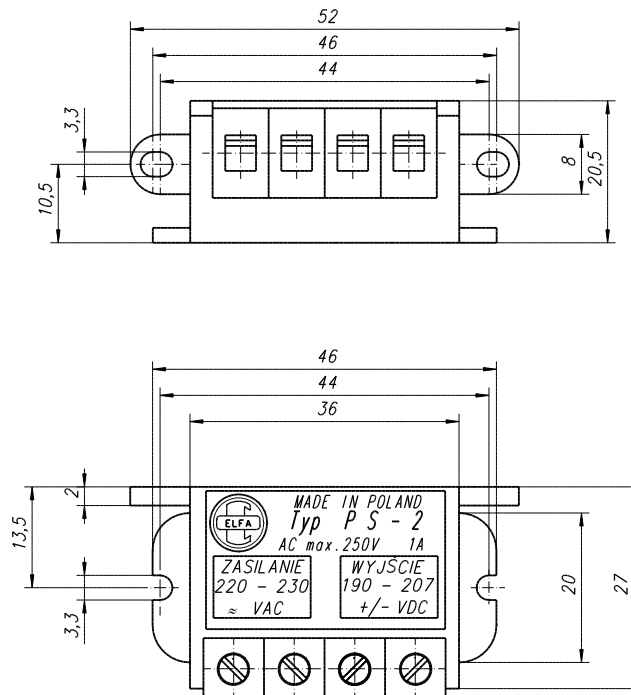

CONTROL AND SIGNALING CIRCUITS – microswitches

Having in mind the user who requires the control of the brake, we have designed special signaling and control circuits, which enable to control the state of the brake (engaged, disengaged) and the wear of the plate lining. The usage of these circuits enables to control the brake with the use of automatic elements, which ensure high level of safety and reliability. Due to its compact design, the microswitch can be used in any other applications, as long as its parameters meet design requirements.

MICROSWITCHES - ELECTRIC PARAMETERS		
Switch parameter	Switch KZ	Switch KO
Max. voltage AC	250 V AC	250 V AC
Max. AC switching current	5 A	6 A
Max. Voltage DC	28V DC	220V DC
Max. DC switching current	3 A / 28V DC	6A / 12V DC 3A / 24V DC 1A / 60V DC 0,5A / 110V DC 0,25A / 220V DC
Protection rating	IP 66	IP 66
Terminals	NO /NC	NO /NC

MICROSWITCH DIMENSIONS

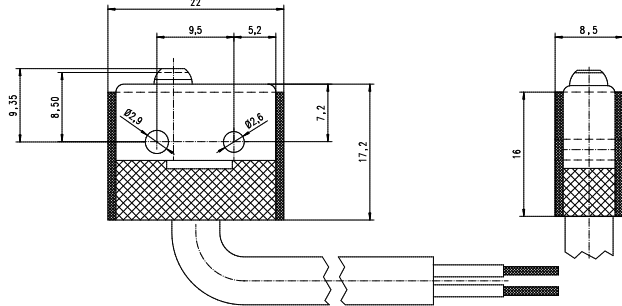

Response monitoring microswitch – KZ – control of the state of brake (engaged, disengaged),

Microswitch of the brake lining control – KO – the microswitch indicates approaching the maximum wear of the brake disc and the necessity of the brake's regulation or replacement of the disc brake, which enables further work of the brake. The regulation procedure is described in the brake operating manual.

Response monitoring microswitch and microswitch of the brake lining control – KZ+KO

[Microswitches set KZ+KO is available from type HPS10 inclusive.](#)

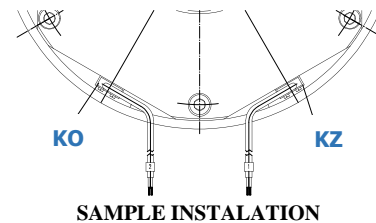

PROTECTIVE CIRCUITS – thermal protection

To protect electromagnet windings against heat build-up (slow-changing overloads) thermal sensor are used. In our offer we have PTC thermistors, which feature high resistance gradients when their rated temperature is reached - posistors - P or bimetallic thermal sensor - B.

Posistor-based sensors are made in the form of an insulated pill with connecting wires extending inside a teflon insulation, installed directly on the electromagnet windings. Sensor circuit terminals are routed outside the brake to the terminal box and connected to a separate connection block or terminal strip. So-called resistance relays are intended for thermistor-based PTC temperature sensors. When temperature of at least one of the sensors rises above the rated value, the circuit resistance suddenly increases triggering the relay.

Posistor thermal protection – P

Note! PTC sensor terminals must not be connected directly to the contactor.

The brake protection has the form of a bimetallic sensor. Brake operation is controlled by a sensor or by a set of sensors, which ensure its safe operation; excessive temperature indication is obtained from the thermal switch installed inside the brake electromagnet's housing rated for a specific temperature. When the limit temperature for the sensor is exceeded, the information for the automatic control equipment is sent or the brake circuit is disconnected.

Bimetallic thermal protection – B

AUXILIARY CIRCUITS – anti-condensation heaters

The so-called parking heating is used to prevent vapours condensation inside the brake. The equipment is particularly useful in negative temperatures or in high humidity environments. The heater is supplied through its dedicated pair of wires. The heater power supply voltage matches customer requirements. – the need to define the voltage during order.

Anti-condensation heaters – GR – ____V

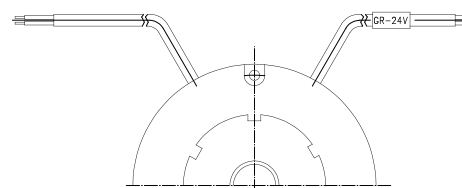

SAMPLE INSTALATION

HPS

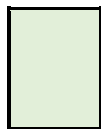

.

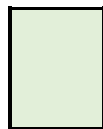

MECHANICAL SIZE
04, 06, 08, 10, 12, 14, 16, 18, 20, 25

CONFIGURATION	
WITHOUT FITTING / ACCESORIES	1
LEVER FOR MANUAL RELEASE	2
MOUNTING FLANGE	3
LEVER FOR MANUAL RELEASE + MOUNTING FLANGE	4

Execution options for the customer's request:

- non-standard diameter of the sleeve gear brake d(H7)
- equipped with heating elements in the winding (need to define the voltage supply) – e.g. **GR__V**
- work at low temperatures -40°C - **Z**
- posistor thermal protection - **P**
- bimetallic thermal protection - **B**
- other voltage brake
- response monitoring microswitch (engaged, disengaged) - **KZ**
- microswitch of the brake lining control - **KO**
- microswitches set - **KZ+KO**
- increased durability of the brake, the brake is guaranteed lifetime 10x10⁶ cycles - brake design allows for long-term and reliable operation HPS06 ÷ HPS10 - **T**

EXAMPLE:

HPS 12. 30. 180 V DC 32 Nm d25 GR104V
 HPS 10. 11. 104 V DC 16 Nm d19 MT
 HPS 14. 22. 24VDC 60Nm d25 KZ+KO



.



VDC



Nm



d



...

DIAMETER OF SLEEVE GEAR d(H7)

CLIMATIC VERSION
ACCORDING TO STANDARDS: e.g. MT, TH

NOMINAL BRAKING TORQUE [Nm]									
HPS 04	HPS 06	HPS 08	HPS 10	HPS 12	HPS 14	HPS 16	HPS 18	HPS 20	HPS 25
4	4	8	20	32	60	100	150	240	500
		6	16	24	45	80	120	180	360
		3	12	16	30	60	75	120	270
			5		40				180

OPERATING VOLTAGE [V DC]
24, 104, 180, 207

PROTECTION RATING	
BASIC VERSION – NUT WITH HOLE D4	0
VERSION IP 54 - WITHOUT HOLE D4	1
VERSION IP 54 - NUT WITH D4 + V-RING SEALING	2
VERSION IP 55 - WITHOUT HOLE D4	3
VERSION IP 55 - NUT WITH D4 + V-RING SEALING	4
VERSION IP 56 - WITHOUT HOLE D4 + IP56 BRAKE COVER	5
VERSION IP 56 - NUT WITH D4 + SPECIAL SEALING + IP56 BRAKE COVER	6

**The producer reserves the right to modify as a result of developing the product.
 It is possible to realize special versions.**